

ACU-SERT™ INSERTER

MODEL: CI-250



ACU-SERT™ INSERTER

CI-250 TECHNICAL SPECIFICATION

Solid Models & Videos Available Online

The AZCO ACU-SERT™ Inserter CI-250 will automatically feed, cut, and dispense sheets for your application. With an optional eye registration system, the unit will cut registered sheets without the need of a printed eye mark. The use of material in roll form will save approximately 20% on the cost of the material compared to pre-cut sheets. Utilizing rolls also reduces labor costs and eliminates operator error. One roll can hold over 30,000 insertions and there is no need to continuously load a magazine, as done with pre-cut sheets.

The inserter feeds and cuts pads, liners, instruction sheets or any flexible material up to 250mm/9" wide. Overwrapped coupons and leaflet pouches may also be fed from a fan folded web.

This unit can be a master or a slave to an existing line and is simple to use and integrate. Requires 110 or 220 Volts 50/60 Hz and 2.75-3 bar (40-60 psi) compressed air.

BENEFITS

- Easy to mount over or alongside a production line
- Easy setup from a color touchscreen
- Adjustable outfeed angle
- Eliminates the need to place sheets by hand
- High productivity; up to 300 inserts per minute
- Low maintenance sealed bearings, rotary knife cartridge

SPECIFICATIONS

- Power requirements: 110 or 220 Volts 50/60 Hz
- 2.75 - 3 bar (40-60 psi) compressed air
- Maximum rate: 300 CPM at under 6"
- Accuracy: +/- 0.38 mm/0.015" or 0.1% of cut length (whichever is larger)

OPTIONS

- Material Flow Package
- Trigger Eye
- Eye Registration
- Jam Sensor
- No-Product Sensor

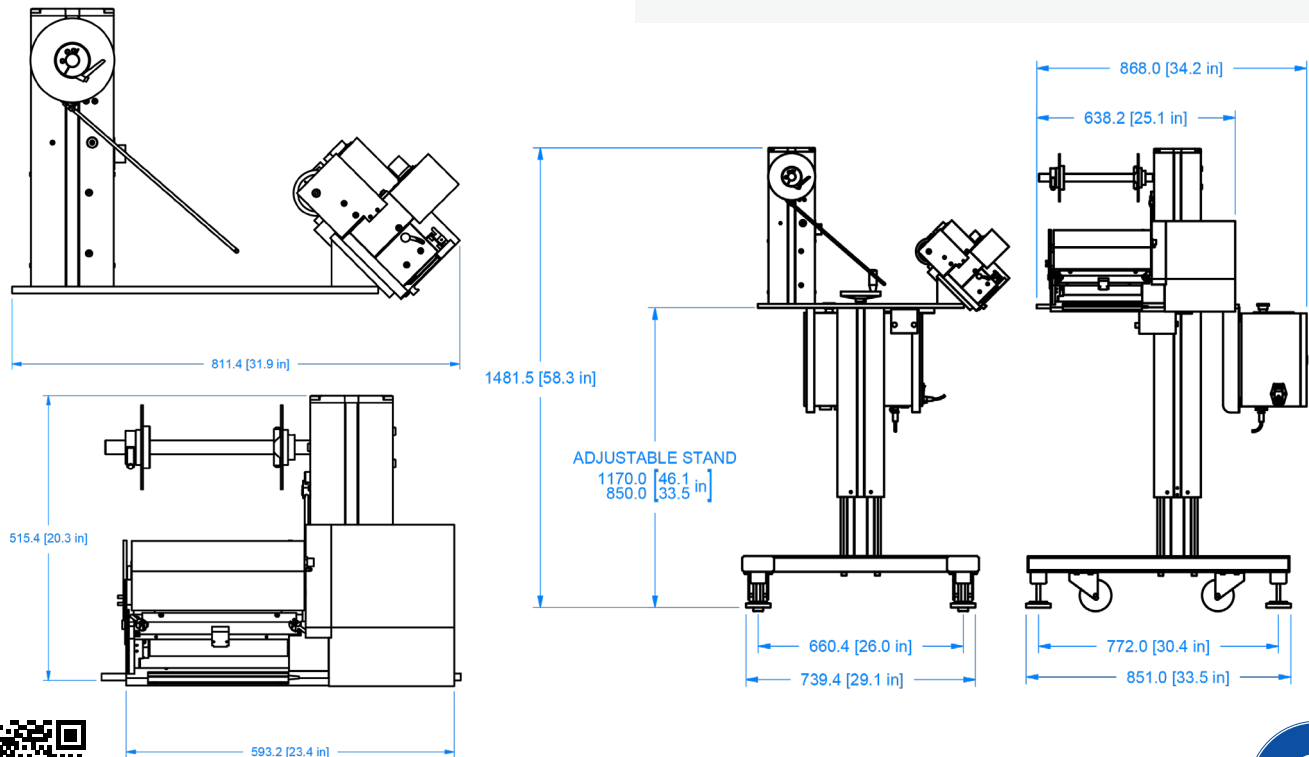

WARNING:

EQUIPMENT MUST BE GUARDED IN ACCORDANCE WITH ALL FEDERAL, STATE, AND LOCAL REQUIREMENTS.

