



THE FUTURE OF PACKAGING

LASER SOLUTIONS FOR THE PACKAGING INDUSTRY



LASER - The Key Technology for the Packaging Market



In today's consumer goods market the customers' buying decision is strongly influenced by shelf presentation and convenient product handling. Thus, converters are more and more often asked to deliver innovative packaging solutions which are one step ahead of the crowd. As glossy high-end printing is very common nowadays, new USPs need to be found.

Laser-optimized packaging makes life easier

The modern customer expects more than just nice printing! Lasers are the key technology for smart packaging with an added value. Laser scribed easy-to-open lines and laser perforated monolayer films for enhanced shelf life of perishable fresh food are already widely used in the food industry.

From Easy Opening to Modified Atmosphere Packaging

Laser-optimized packaging is simply better. There is no need to explain the benefit of a laser scribed easy tear line on a doypack, not only for the growing elderly population. Various other aspects promote the use of micro-perforated pouches for salad and vegetables. Controlled oxygen exchange considerably enhances perishables' shelf life which also leads to less waste, reduces overall costs and helps to protect the environment.

**Discover how
ROFIN's laser technology
smartens up your
packaging!**

ROFIN - The Market Leader for Laser Solutions in the Packaging Industry - the New StarPack® Line

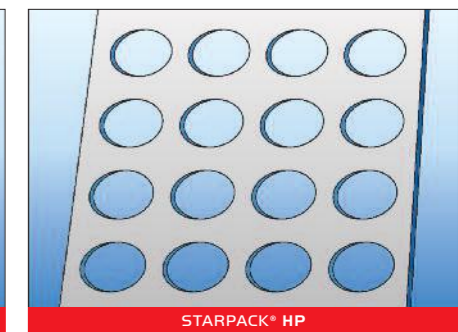
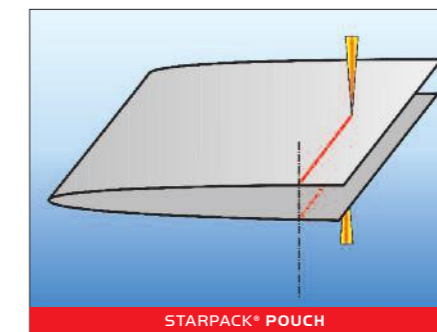
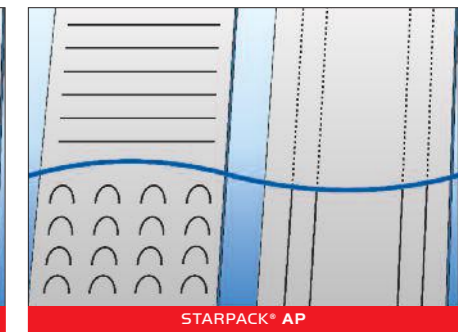
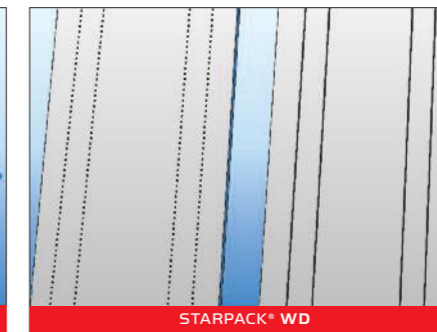
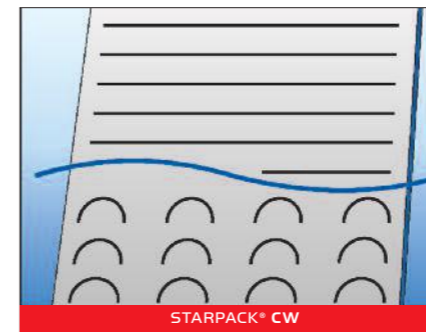

With more than 52.000 systems installed worldwide, the ROFIN group is a market and innovation leader for lasers and laser-based solutions for industrial materials processing. No matter whether it is cutting, welding, marking or surface treatment, whether it is a CO₂, fiber, solid state, diode or ultra-short pulsed laser - ROFIN offers the optimal laser technology today for the applications of tomorrow.

ROFIN's CO₂ expert group in Gilching near Munich is the market leader for laser-optimized flexible packaging and co-operates with the major packaging converters. The comprehensive knowledge about packaging material gained during many years of experience helps to design new laser sources tailored for this important market. ROFIN develops laser processes for the packaging industry on their own winding system and lab equipment. Customers are welcome to send material for free trials.

The StarPack® Product Line
The comprehensive but straightforward product line-up. Each StarPack model provides the basis for a tailor-made solution.

StarPack® CW
Cross web applications and free form scribing

StarPack® WD
Web direction scribing and perforating within one process

StarPack® AP
Cross web and web direction in one system

StarPack® HP
High-power scribing and cutting of thick material

StarPack® Pouch
For integration in pouch making machines

StarPack® CW

StarPack® WD



STARPACK® CW



ANY FORMS



MULTIPLE SCAN HEADS



UP TO 9 GALVOS POSSIBLE

Cross-web applications and free form scribing
 StarPack® CW systems are designed for selective scribing of packaging layers in the cross-web direction. This corresponds to the typical manufacturing process of bags and pouches. Beyond that, StarPack® CW systems can make arbitrarily shaped scribing lines, suitable for re-closable flaps or circular easy tear lines in the corners of packaging.

High performance scanner heads with with 2 or 3 axes offer extremely fast beam positioning with an enormous working field. The goal is subtle, visually unobtrusive scribing lines. Depending on the application, web width and other customer's requirements, ROFIN mounts up to 9 laser sources on a StarPack® CW system. Typically ROFIN's laser solutions are integrated into the slitter winder.

ROFIN's sophisticated controlling software assures precise laser beam positioning and complete web movement compensation. The selective weakening of packaging layers is achieved by precisely controlling the laser energy. Three different wavelengths facilitate optimum adjustment to the absorption properties of the selected packaging films.



STARPACK® WD



FINEST EASY-TEAR LINES



VARIOUS MATERIALS



MODULAR SYSTEM



ON 2 LEVELS

Web direction scribing and perforating within one process
 With up to 8 processing heads as a standard - more are available on request - StarPack® WD systems handle almost any web direction application. The main application area is the perforation of packaging films for fresh food to obtain a controlled atmosphere within the packaging. Hole sizes for this type of application are in the range of 50 µm to 300 µm depending on the material. Thanks to its newly developed controlling software scribing and perforating can be combined within one process! The software allows the mixing of hole sizes, scribing lengths and patterns all at the same time. This allows for straightforward cost-efficient manufacturing of packaging with controlled atmosphere and easy opening functionality in web-direction.

The StarPack® WD is designed to accommodate up to 2 laser sources as a standard - more are available on request. As with all StarPack® systems, scribing and perforating is being synchronized with the package print. For optimum processing of thick packaging films and demanding composite material at high web speed, the system can be equipped with ROFIN's web movement compensation (WMC).

StarPack® AP

StarPack® AP - The Entire Range of ROFIN's Scribing and Perforating Knowhow in One Solution



STARPACK® AP



3 AXIS GALVO FOR CW SCRIBING



FIXED OPTICS FOR WD SCRIBING & PERFORATION



ROFIN LASER SOURCES WITH DIFFERENT WAVELENGTHS



STABLE FRAME WORKS

The universal solution
The StarPack® AP (All Purpose) is the packaging all-rounder, combining CW and WD functionality in one system. This makes it an ideal choice for complex manufacturing processes and for converters who want to be perfectly prepared for customers' future requirements.

Each scribing and perforation application differs. Various components of a laser system have great influence on the properties of a scribing line or the size of a perforated hole: laser source, galvo scanner or laser optics. The StarPack® AP offers the entire range that modern laser technology can provide for the packaging industry.

Even different types of lasers can be integrated within one system. The StarPack AP provides the basis for future all-round solutions that enable you to meet all customer needs.

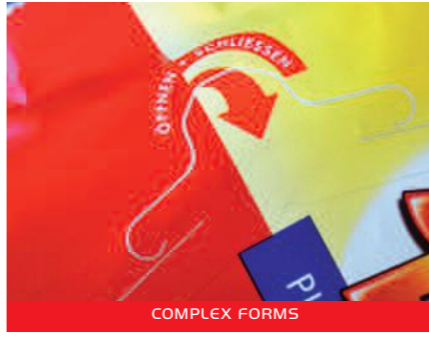

COMPLEX FORMS



SIMPLE FORMS AT HIGHEST WINDING SPEED



CLASSIC EASY-TEAR LINE



DOUBLE EASY-TEAR LINE

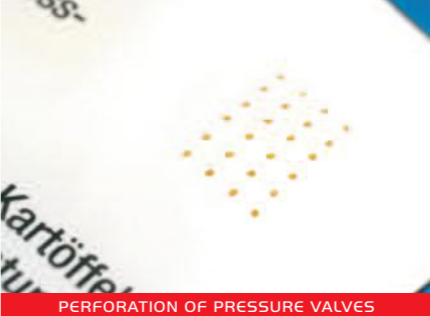

PERFORATION OF PRESSURE VALVES



CLASSIC PERFORATION OF BOPP

Complex contours
Up to 9 lasers and deflection units realize highly-complex scribing lines at high web-speed.

Dual easy-tear line
Precise double-spot focusing lenses are used for splitting the laser beam, resulting in dual easy tear lines which help to optimize easy opening.

Simple shapes at utmost web speed
High-end scanner heads scribe commonly used semi- and quarter-circular opening lines at several hundred meters per minute.

Perforating of pressure valves for microwaveable packaging
Perforation of a row or a small area of micro holes enables a valve-like functionality for microwaveable packaging. The steam which develops during preparation escapes through the tiny holes.

Classic simple easy-tear line
Especially single-portion sachets, e.g. for instant coffee (3 in 1) require cross web scribing on the winder. Web speeds of up to 500 m/min are possible for this application.

Classical perforation of BOPP
The StarPack® AP also handles the standard micro perforation e.g. of pouches for salads or vegetables. BOPP mono layer film is perforated with 3 - 8 micro holes. This enhances shelf life up to one week. Equipped with the innovative WMC module, perfect circular holes from 50 µm - 300 µm diameter - depending on the material - can be perforated even at high web speed.

StarPack® Pouch

StarPack® HP

ROFIN – CO₂ Systems with Own Developments for the Flexible Packaging Industry



STARPACK® POUCH

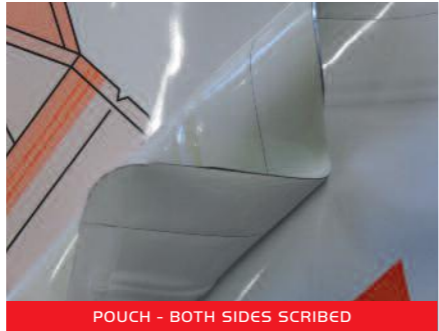

POUCH - BOTH SIDES SCRIBED

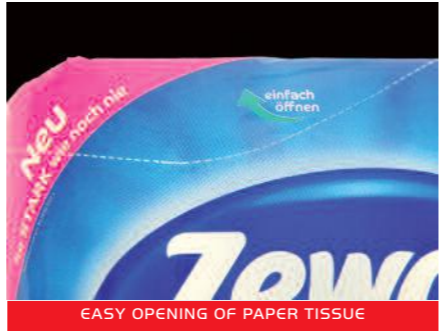

EASY OPENING OF PAPER TISSUE



STARPACK® HP

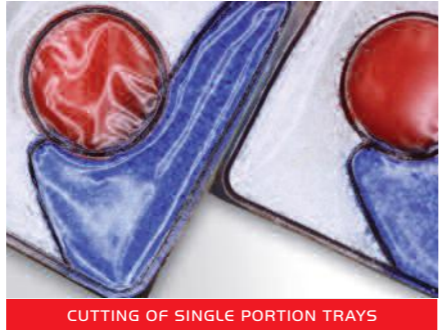

CUTTING OF SINGLE PORTION TRAYS



CARDBOARD CUTTING

Compact solution for pouch making machines

The space-saving, compact system, designed for integration in pouch making machines, complements the range of laser systems for easy opening. It provides a solution for food producers who are looking for a laser scribing system that can be used directly after pouch forming or within the form fill and seal unit.

As web speed in pouch making systems is considerably lower than in slitter winders, 100 W laser power is more than sufficient for optimum scribing results. StarPack® Pouch is the cost-efficient alternative using low power laser sources and simultaneously offers easy integration.

High power scribing and cutting of thick packaging material

Cutting and scribing of thick packaging material such as cardboard and thermoforming films is a promising new application area for laser systems. Compared to a laser, mechanical cutting and punching techniques are prone to wear and tear and require cost-intensive modifications every time the package design changes.

With laser sources from 1000 W to 2500 W the StarPack® HP cuts even thick packaging material on-the-fly at full web speed. A new high-end scanner system has been especially designed for this type of application and laser sources with a power of more than 2000 W. With an impressive working area of over 1 m² and at the same time very small spot sizes, the StarPack® HP is a true alternative to a punch.

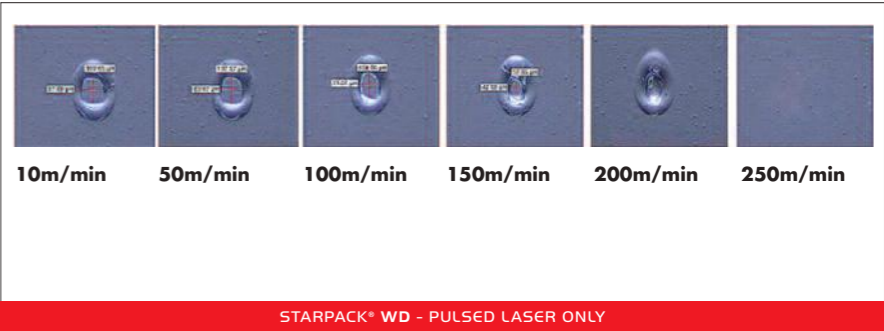

10m/min 50m/min 100m/min 150m/min 200m/min 250m/min

STARPACK® WD - PULSED LASER ONLY

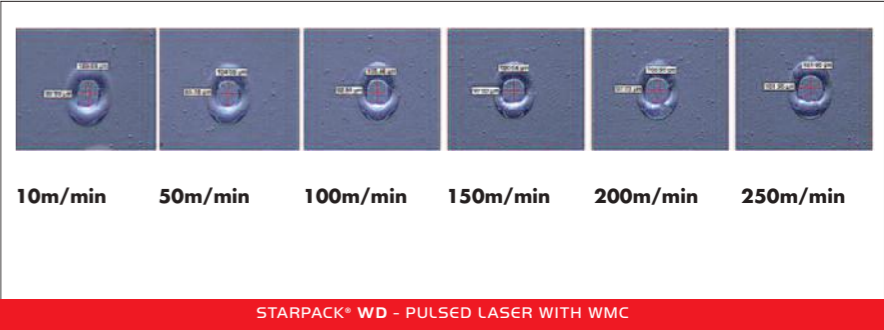

10m/min 50m/min 100m/min 150m/min 200m/min 250m/min

STARPACK® WD - PULSED LASER WITH WMC

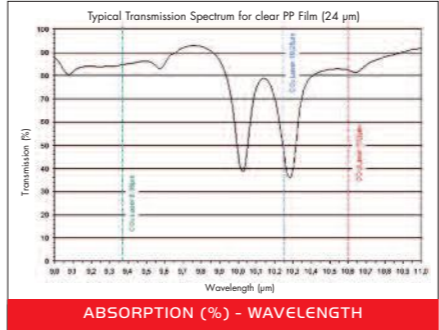

ABSORPTION (%) - WAVELENGTH

The right wavelength makes the difference

The various polymers which are commonly used in the packaging industry show different absorption properties at 10.6 μm, which is the industrial standard wavelength of CO₂ laser sources. Especially polypropylene can be processed considerably faster at shorter wavelengths. Consequently, lasers with 10.25 μm wavelength realize tremendous higher scribing and perforating speeds for PP-based polymers.

ROFIN is the only laser manufacturer who has the capability to drive its development of new laser sources towards the benefit of the flexible packaging companies. The result is a CO₂ laser range from 10.60 μm to 10.25 μm to 9.35 μm at various power levels.

WMC – Precision perforation at all times

The packaging industry calls for perforation with perfect and consistent quality. The better the perforation the bigger the shelf life advantage. Multi-chamber trays require different perforation to optimize the storage life of the contents in all particular chambers.

ROFIN's web movement compensation (WMC) system provides complete compensation of web movement and safeguards perfect circular holes of the desired size under all conditions. Thus production waste is reduced significantly and maximum web speed more than doubles. The solution encompasses a comprehensive speed range, from 0 m to more than 380 m per minute and can be fitted and retrofitted in all StarPack® WD and AP systems.

StarFLEX

The All-in-one Graphical User Interface for All Laser Systems

StarMAP

The Smart Software Solution to Define High Precision Perforation Parameters

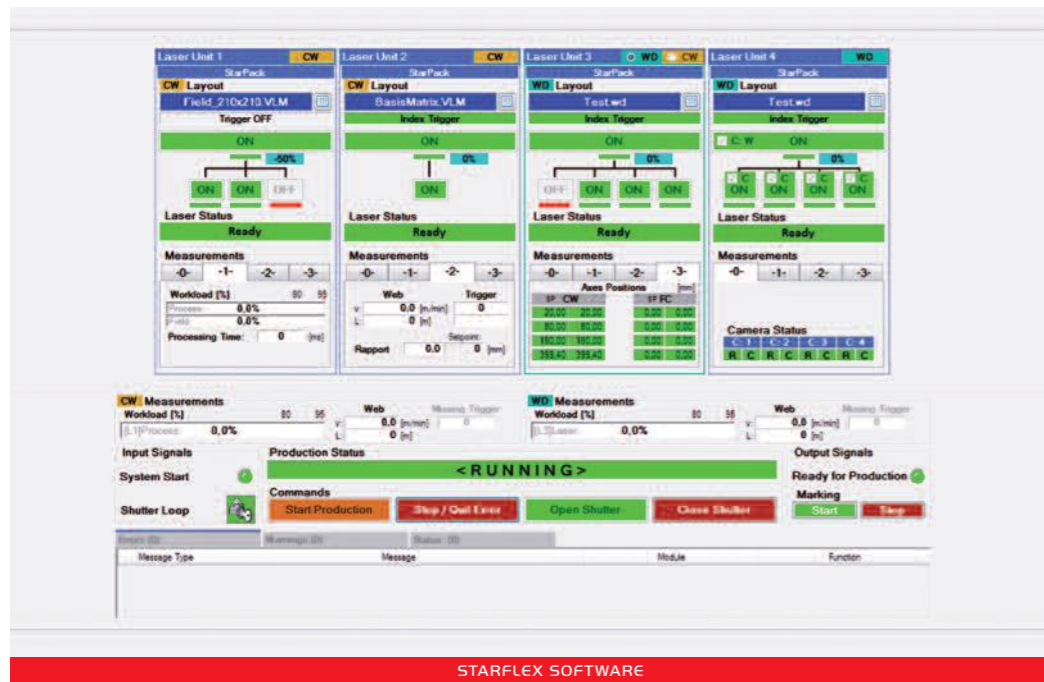

STARFLEX SOFTWARE

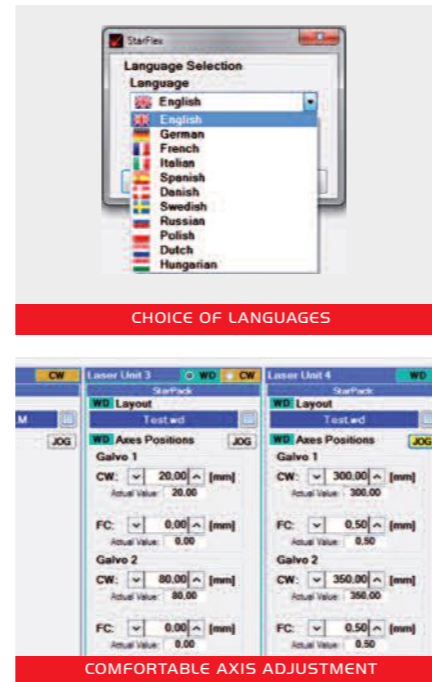

COMFORTABLE AXIS ADJUSTMENT

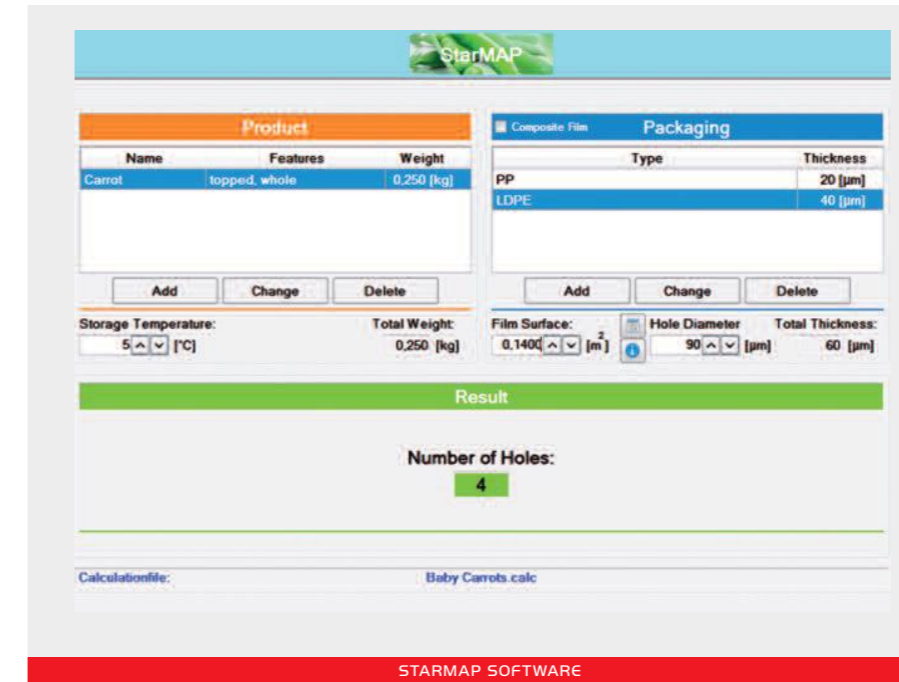

STARMAP SOFTWARE



MATERIAL TYPE CONSIDERED

StarFLEX

The software developed by RoFin for all flexible packaging applications

StarFlex can control web direction and cross web systems at the same time. Each laser source and processing head can be activated separately. All necessary parameters, like offset, rapport length and trigger features can be intuitively adjusted and saved to the layout. Each laser can run with a different layout and parameter recipe. To create a layout the access to the RoFin editors VLM and WD is embedded in StarFLEX.

In addition, various components like motorized focus axis and positioning axis can be easily controlled by the software. These settings are saved in the parameter recipe as well. An automatic power measurement allows you to record the quality of your laser.

Quality, convenience and safety with the graphical user interface StarFLEX

A sophisticated trigger control allows you to guarantee your customer a 100% check of the eye marks. Each missed mark is reported and you can define when the system will automatically stop. For operator convenience the language of the software can be changed by one click. Meanwhile more than 12 languages are available. For your safety you can define access rights for different employees.

StarFLEX provides the following information:

- Current web speed
- Running length
- Real time distance of trigger rapport
- Number of trigger
- Detailed workload status of each laser system
- Processing time

StarMAP

The smart software solution to provide precisely the number of holes for various packaging designs

When shopping fresh products customers definitely choose the products, which look fresh.

It is well-known perforation of the packaging film extends product's shelf life and preserves its good looks for a longer period of time – but how many holes for which product?

ROFIN's StarMAP software has the answer! It provides the ideal hole number of a certain size to guarantee high product quality of the packed goods. Based on an USDA approved database it uses a scientific approach to calculate correct hole number for an optimized OTR value. This makes long test series become history.

To provide the best possible shelf life and product quality, StarMAP takes the following parameters into account:

- Product: fruits, vegetables, whole/fresh cut
- Product volume
- Storage temperature
- Type of packaging film
- Packaging geometry

Reliable calculation of the hole number for different products based on your own database

The software can be used with any ROFIN web direction laser system solution for perforation like StarPACK® WD and StarPACK® AP.

The software is bringing numerous benefits to film and packaging suppliers as well as food processors e.g.:

- Reliable calculation of micro-perforation
- Fast and easy adaption to different products and types of packaging
- Less costly and time consuming trial & error
- Reduced waste
- Easy to use and comfortable user interface
- All contained database information is yours
- Optional device for measurement of respiration rates on site to create your own additional database

O₂-Check Kit - Individual MAP Optimization Package

VisionPerfoControl



O₂-CHECK KIT



VARIOUS PRODUCTS - REGIONS - GROW & HARVEST CONDITIONS

StarMap comes with an USDA approved database of more than 160 products (fruits, vegetables, whole / fresh cut). This database is a good point to start from. But there is still room for optimization and major converters are already addressing this point.

However oxygen-transmission rates of fresh food vary, as growing area and harvest time have a certain influence. With the O₂-Check Kit, ROFIN now opens the same possibilities for small and medium-sized converters. It comes with a sensor-equipped, air-tight container, a highly temperature-stable climate cabinet and smart evaluation software.

With O₂-Check Kit adapting your micro-perforation pattern to varying circumstances is a breeze. Just put a sample in the sensor-equipped test-box and place it in the climate cabinet. The software will record the oxygen-transmission rates over

time and generate a new database record for this specific product. With this new solution every converter will be able to offer individually and seasonally optimized modified atmosphere packagings for fresh produce.

- All-in-one package, includes hard and software
- Simple and user-friendly measurement process
- Automatic database update
- Individual and seasonal MAP-optimization

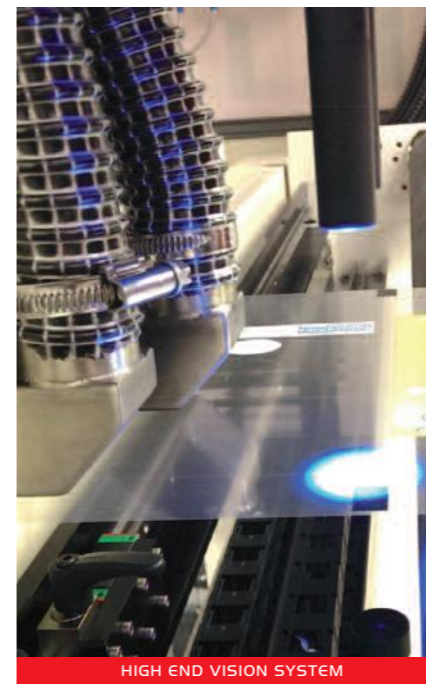

HIGH END VISION SYSTEM

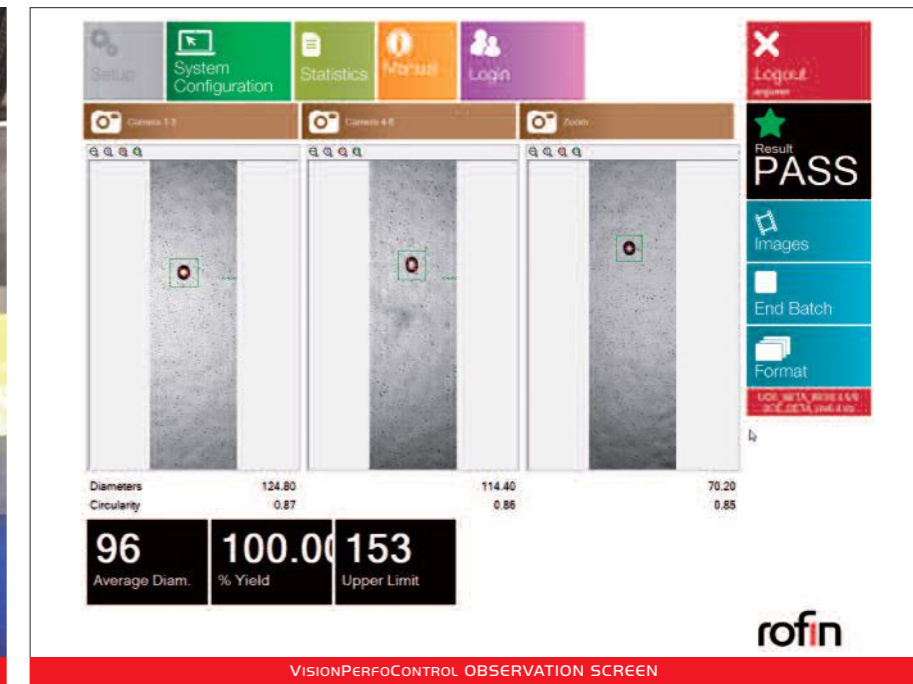

VISIONPERFOCONTROL OBSERVATION SCREEN

True, real-time monitoring of the perforation process to ensure consistent quality and diameter of the holes is a demanding task. Typically, perforation holes have diameters less than 120 microns while the packaging film moves with some 100 m/min. Consequently, there have been no ready-to-use solutions on the market up to now. ROFIN is the first supplier to offer true real-time monitoring of perforation hole diameter and percentage roundness. Each laser perforation head will be fitted with a high-speed camera and the output of each camera is processed using pattern recognition software to record accurately the dimensions of each hole.

VisionPerfoControl allows for validation of the hole perforation process and eliminates the possibility of incorrect set up (e.g. focus error) from spoiling the output from the perforation system. Furthermore, the recorded data documents 100% perforation quality of the processed material.

- True, real-time monitoring of perforation quality
- Checking roundness and diameter
- No production waste due to incorrect set up
- 100% quality control documentation

Specifications

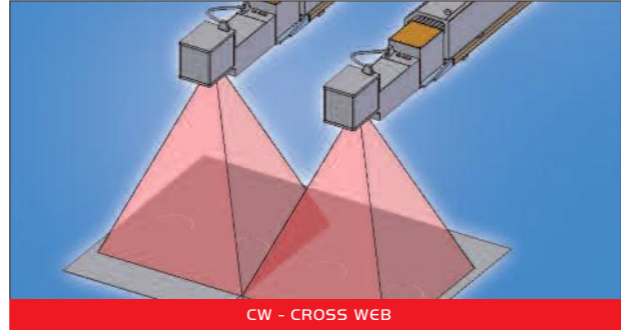
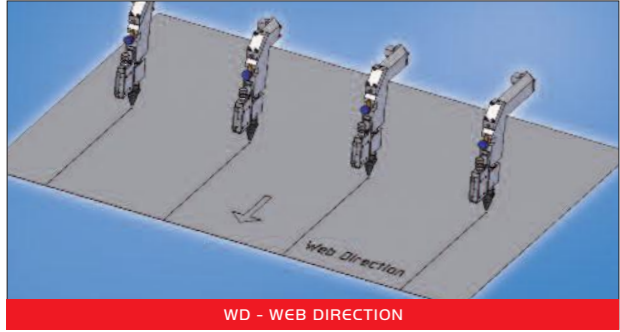

StarPack®	WD	CW	AP	Pouch	HP
Free Form Contour Scribing	no	yes	yes	no	yes
Multiple Head Web Direction Scribing	yes	(x)*	yes	yes	(x)*
Max. Number of Individual Scribing Lines <small>more on request</small>	2/4/6/8	1 - 9 WD 2/4/6/8 <small>more on request</small>	CW 9	2	1
Number of Lasers	1 - 9	1 - 9	1 - 9	1	1 - 9
Power per Laser	100-650 W	100-650 W	100-650 W	100-200 W	1000-2500 W
Number of Super Fast Galvo Heads	-	1 - 9	1 - 9	-	1 - 9
Tailor-made Safety Housing (class 1) & Frame Works	optional	yes	yes	yes	optional
Web Width	up to 1800 mm	up to 1800 mm	up to 1800 mm	up to 1800 mm	up to 1800 mm
Web Speed (depending on material)	700 m/min	600 m/min	600 m/min	600 m/min	600 m/min
Web Movement Compensation (WMC)	yes	no	yes	no	no

(x)* Galvo mirrors can be switched to a fixed position to scribe in web direction.

Sample

EASY OPENING - LASER SCORED

MICRO PERFORATION

STEAM RELEASE

EASY OPENING

CUTTING

BAASEL LASERTECH

Add value to your Packaging!
For the convenience of consumers.

GET FREE SAMPLES!
For ordering contact:
co2systems-micro@rofin.de

ROFIN-BAASEL Lasertech
 GmbH & Co. KG
 Zeppelinstraße 10
 82205 Gilching
 Germany
 Phone +49 8105-3965-0
 Fax: +49 8105-3965-4159
 E-mail: co2systems-micro@rofin.de

ROFIN-SINAR Laser GmbH
 Berzeliusstraße 87
 22113 Hamburg
 Germany
 Phone +49 40 733 63 0
 Fax: +49 40 733 63 4100
 E-mail: sales-macro@rofin.de

ROFIN-SINAR Laser GmbH
 Dieselstraße 15
 85232 Bergkirchen-Günding
 Germany
 Phone +49 8131 704 0
 Fax: +49 8131 704 4100
 E-mail: sales-marking@rofin.de

WWW.ROFIN.COM

Benelux: Phone +31 78 69310 37
 E-mail: info@rofin-baasel.nl

CA: Phone +1 905 607 0400
 E-mail: info-canada@rofin-inc.com

CH: Phone +41 32 322 1010
 E-mail: info@rofin-baasel.ch

CN: Phone +86 21 68552216
 E-mail: info@rofin-baasel.com.cn

ES/PT: Phone +34 93 4770 644
 E-mail: info@rofin-es.com

F: Phone +33 1 6911 3636
 E-mail: info@rofin.fr

IN: Phone +91 22 276125 1
 E-mail: sales.micro@rofin.in

IT: Phone +39 039 27291
 E-mail: info@rofin.it

JP: Phone +81 46 229 8655
 E-mail: info@rofin-baasel.co.jp

KR: Phone +82 2 837 1750
 E-mail: info@rofin.co.kr

SG: Phone +65 6482 1091
 E-mail: reception@rofin-baasel.com.sg

TW: Phone +886 2 2790 1300
 E-mail: sales@rofin-baasel.com.tw

UK: Phone +44 1327 701 100
 E-mail: sales@rofin-baasel.co.uk

US: Phone +1 734 455 5400
 E-mail: info@rofin-inc.com

Find further representatives and partners on www.rofin.com/worldwide

